



# CAMPEONATO RALLY ARGENTINO 2017



**04**  
**FECHA**

**LIBRO DE RUTA**



**47º FIESTA NACIONAL E INTERNACIONAL DEL PONCHO**



MADE PROMOTORS



Ministerio de Turismo  
Presidencia de la Nación



SPONSORS OFFICIALS





















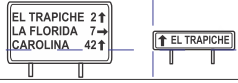

WORLD SPECIAL









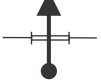

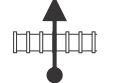



PROMOTORES OFICIALES







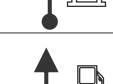







Simbolo	Significado
	Control Horario
	Largada Prueba Especial
	Final Prueba Especial
	Stop
	Radio
	Ambulancia
	Bomberos
	Precaución
	Peligro
	Muy peligroso
	Atención Angosto
	Señal de Celular
	Sin Señal de Celular

Simbolo	Significado
	Lomada sobre asfalto
	Lomo o lomada sobre tierra
	Vado o Baden Seco
	Vado o Baden con Cruce de Agua
	Corte con Cruce de Agua
	Corte Seco
	Cartel rutero indicador
	<p>EL TRAPICHE 2↑ LA FLORIDA 7→ CAROLINA 42↑</p> <p>↑ EL TRAPICHE</p>
	Dirección a seguir
	Número de figura
	No utilizar lo cruzado con diagonales
	Camino Asfaltado
	Camino de tierra / ripio
	Prueba Especial Número de figura Distancia Regresiva
	Puente
	Alcantarilla
	Guardaganado
	Ingresar por tranquera

Simbolo	Significado
	Vías ferrocarril
	Parques de Servicio
	Alambrado
	Arbol
	Cementerio
	Casa
	Escuela
	Iglesia o Capilla
	Hospital
	Piedra / Pirca
	Postes de electricidad
	Refugio
	Estación de Servicio

||

Simbolo	Significado
	Sendero
	Mojón indicador Kilometraje de ruta
	Semaforo
	Plaza / Plazoleta
	Hotel / Hostería
	Fabrica
	Tranquera en alambrado lateral
	Antena
	Gruta
	Camino en ascenso o Camino en descenso
	Camino sinuoso
	Estación de Peaje
	Alambrado olimpico

<b>CH</b>	<b>Predio Ferial - Parque de Servicio</b>	<b>Distancia</b>	<b>Etapa</b>	<b>Pag.</b>
<b>CH</b>	<b>Predio Ferial - Shakedown</b>	<b>0.78</b>	<b>Sector</b>	<b>III</b>
<b>Nro.</b>	<b>PRUEBA ESPECIAL</b>	<b>Kms.</b>	<b>Promedio</b>	<b>Tiempo Otorgado</b>
	<b>ENLACE</b>		<b>kms.</b>	

Distancia		Dirección	Información	Distancia Regresiva
Total	Parcial			
<b>0.00</b>	<b>0.00</b>	<p><b>1</b></p>	<b>CH Sh</b> Salida Parque de Servicio Predio Ferial Catamarca Portón 6 GPS: S 28 26 922 W 65 45 321 ALT. 531	<b>0.78</b>
<b>0.10</b>	<b>0.10</b>	<p><b>2</b></p>		<b>0.68</b>
<b>0.17</b>	<b>0.07</b>	<p><b>3</b></p>		<b>0.61</b>
<b>0.78</b>	<b>0.61</b>	<p><b>4</b></p>	<b>CH Sh</b> En Cuanto cruza vereda.	<b>0.00</b>





LPE	Shakedown		Distancia	Etapa	Pag.
CH	Predio Ferial - Parque de Servicio		<b>4.08</b>		<b>V</b>
			kms.	Sector	
Nro.	PRUEBA ESPECIAL		Kms.	Promedio	Tiempo Otorgado
	<b>SHAKEDOWN</b>		<b>2.25</b>		

Distancia		Dirección	Información	Distancia Regresiva
Total	Parcial			
0.00	0.00		<b>LPT</b> En Cartel de Peligro GPS: S 26 26 729 W 65 45 454 ALT. 534 <small>1er. Auto 12:00 hs.</small>	<b>4.08</b>
1.10	1.10			<b>2.98</b>
1.40	0.30			<b>2.68</b>
1.50	0.10			<b>2.58</b>
2.00	0.50			<b>2.08</b>
2.25	0.25		<b>FPT</b> En poste de cemento con letra B. GPS: S 28 26 160 W 65 45 643 ALT. 543	<b>1.83</b>

LPE	Shakedown		Distancia	Etapa	Pag.
CH	Predio Ferial - Parque de Servicio		4.08	Sector	VI
Nro.	PRUEBA ESPECIAL	Kms.	Promedio	Tiempo Otorgado	
	<b>SHAKEDOWN</b>		2.25		

Distancia		Dirección	Información	Distancia Regresiva
Total	Parcial			
2.35	0.10			1.73
2.48	0.13		<p>En calle sobre derecha.</p>	1.60
3.07	0.59			1.01
3.15	0.08		Por Asfalto.	0.93
3.22	0.07			0.86
3.55	0.33		<p>Si gira a la izquierda vuelve a Largada de Shakedown.</p>	0.53

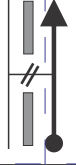
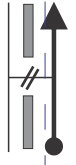
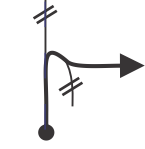
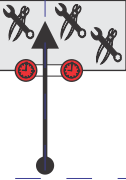







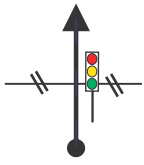

LPE	Shakedown		Distancia	Etapa	Pag.
CH	Predio Ferial - Parque de Servicio		4.08	Sector	VII
Nro.	PRUEBA ESPECIAL	Kms.	Promedio	Tiempo Otorgado	
	SHAKEDOWN		2.25		

Distancia		Dirección	Información	Distancia Regresiva
Total	Parcial			
3.85	0.30	 13		0.23
3.95	0.10	 14		0.13
4.02	0.07	 15		0.06
4.08	0.06	 16	 <b>CH</b> Ingreso - Parque de Service Predio Ferial Catamarca PORTON N°7 GPS: S 28 26 891 W 65 45 338 ALT. 533	0.00

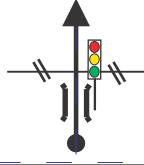

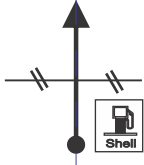

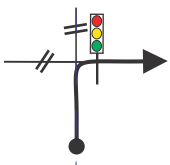

CH	Predio Ferial - Parque de Servicio	Distancia	Etapa	Pag.
CH	Parque de Largada	<b>4.92</b>	Sector	<b>VIII</b>
Nro.	PRUEBA ESPECIAL	Kms.	Promedio	Tiempo Otorgado
<b>ENLACE</b>			kms.	

Distancia		Dirección	Información	Distancia Regresiva
Total	Parcial			
0.00	0.00	<p><b>1</b></p>	<p><b>CH Sh</b> Salida Parque de Servicio Predio Ferial Catamarca Portón 6</p> <p>GPS: S 28 26 922 W 65 45 321 ALT. 531</p>	<b>4.92</b>
0.10	0.10	<p><b>2</b></p>		<b>4.82</b>
0.18	0.08	<p><b>3</b></p>		<b>4.74</b>
0.78	0.60	<p><b>4</b></p>		<b>4.14</b>
1.15	0.37	<p><b>5</b></p>	Por Av. Arnaldo Castillo	<b>3.77</b>
2.15	1.00	<p><b>6</b></p>		<b>2.77</b>

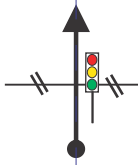

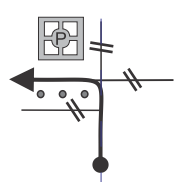

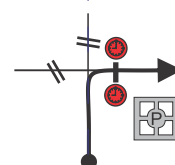





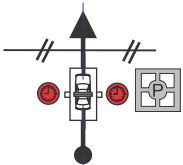

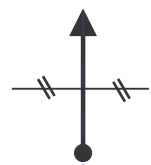
CH	Predio Ferial - Parque de Servicio	Distancia	Etapa	Pag.
CH	Parque de Largada	<b>4.92</b>	Sector	<b>IX</b>
Nro.	PRUEBA ESPECIAL	Kms.	Promedio	Tiempo Otorgado
<b>ENLACE</b>			kms.	

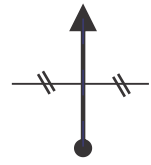
Distancia		Dirección	Información	Distancia Regresiva
Total	Parcial			
2.85	0.70	 7		2.07
2.95	0.10	 8	 Técnica Previa a la derecha TOYOTA DEL PARQUE <div style="border: 1px solid black; padding: 2px; width: fit-content;">           GPS:            S 28 27 510            W 65 46 202            ALT. 512         </div>	1.97
3.15	0.20	 9	<b>Semáforo</b> Cruza Belgrano Continúa por Av. Alen  Zona Urbana	1.77
3.65	0.50	 10	<b>Semáforo</b>  Zona Urbana	1.27
3.83	0.18	 11	 Zona Urbana	1.09
3.95	0.12	 12	<b>Semáforo</b> Por calle República  Zona Urbana	0.97

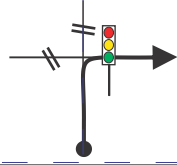
CH	Predio Ferial - Parque de Servicio	Distancia	Etapa	Pag.
CH	Parque de Largada	<b>4.92</b>	Sector	<b>X</b>
Nro.	PRUEBA ESPECIAL	Kms.	Promedio	Tiempo Otorgado
	<b>ENLACE</b>		kms.	

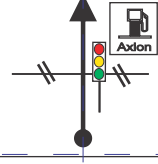
Distancia		Dirección	Información	Distancia Regresiva
Total	Parcial			
4.50	0.55	 13	<b>Semáforo</b> Cruza Tucumán  Zona Urbana	0.42
4.81	0.31	 14	Por calle Rivadavia  Zona Urbana	0.11
4.92	0.11	 15	 <b>CH</b> Ingreso - Parque de Largada Por calle San Martín	0.00

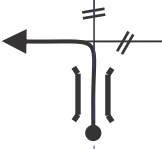
CH	Rampa de Largada Simbólica	Distancia	Etapa	Pag.
CH	Predio Ferial - Parque de Servicio	<b>4.43</b>		<b>XI</b>
		kms.	Sector	
Nro.	PRUEBA ESPECIAL	Kms.	Promedio	Tiempo Otorgado
	<b>ENLACE</b>			
			kms.	



Distancia		Dirección	Información	Distancia Regresiva
Total	Parcial			
0.00	0.00	 <p><b>1</b></p>	 <p><b>LSP</b> Largada Simbólica Promocional Por calle Sarmiento</p> <p>GPS: S 28 28 105 W 65 46 780 ALT. 533</p>	<b>4.43</b>
0.15	0.15	 <p><b>2</b></p>	 <p>Zona Urbana</p>	<b>4.28</b>
0.76	0.61	 <p><b>3</b></p>	<p>Cruza Peru</p>  <p>Zona Urbana</p>	<b>3.67</b>
0.90	0.14	 <p><b>4</b></p>	<p><b>Semáforo</b> Por Av. Belgrano</p>  <p>Zona Urbana</p>	<b>3.53</b>
1.32	0.42	 <p><b>5</b></p>	<p><b>Semáforo</b></p>  <p>Zona Urbana</p>	<b>3.11</b>
1.85	0.53	 <p><b>6</b></p>	<p>Por Av. Castillo</p>  <p>Zona Urbana</p>	<b>2.58</b>

CH	Rampa de Largada Simbólica	Distancia	Etapa	Pag.
CH	Predio Ferial - Parque de Servicio	<b>4.43</b>		<b>XII</b>
Nro. PRUEBA ESPECIAL		Kms.	Promedio	Tiempo Otorgado
<b>ENLACE</b>			kms.	

Distancia		Dirección	Información	Distancia Regresiva
Total	Parcial			
1.90	0.05	<p>7</p>		2.53
2.98	1.08	<p>8</p>		1.45
3.40	0.42	<p>9</p>		1.03
3.95	0.55	<p>10</p>		0.48
4.20	0.25	<p>11</p>		0.23
4.30	0.10	<p>12</p>		0.13

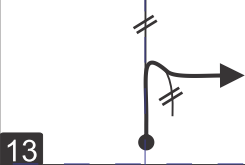
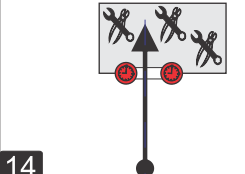

CH	Rampa de Largada Simbólica	Distancia	Etapa	Pag.
CH	Predio Ferial - Parque de Servicio	<b>4.43</b>		<b>XIII</b>
		kms.	Sector	
Nro.	PRUEBA ESPECIAL	Kms.	Promedio	Tiempo Otorgado
	<b>ENLACE</b>		kms.	

Distancia		Dirección	Información	Distancia Regresiva
Total	Parcial			
4.37	0.07			0.06
4.43	0.06		 <b>CH</b> Ingreso - Parque de Service Predio Ferial Catamarca PORTON N°7 GPS: S 28 26 891 W 65 45 338 ALT. 533	0.00



**Día 1- Sección 1**







**Etapas 1**

**24 de Junio del 2017**

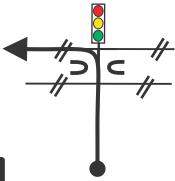

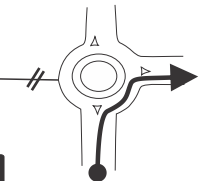

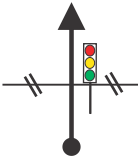
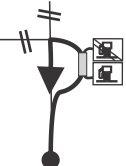

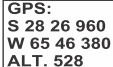
<b>CH 0</b>	<b>Parque de Servicio - Salida</b>	<b>Distancia</b> <b>39.32</b> kms.	<b>Etapa 1</b>	<b>Pag.</b>
<b>CH 1</b>	<b>Banda Sur</b>		<b>Sector 1</b>	<b>1</b>
<b>Nro.</b>	<b>PRUEBA ESPECIAL</b>	<b>Kms.</b>	<b>Promedio</b> <b>52.42</b> kms.	<b>Tiempo Otorgado</b> <b>45'</b>
<b>ENLACE</b>				

Distancia		Dirección	Información	Distancia Regresiva
Total	Parcial			
<b>0.00</b>	<b>0.00</b>		<b>CH 0</b> Salida Parque de Servicio Predio Ferial Catamarca Portón 6 <b>GPS:</b> S 28 26 922 W 65 45 321 ALT. 531	<b>39.32</b>
<b>0.10</b>	<b>0.10</b>			<b>39.22</b>
<b>0.15</b>	<b>0.05</b>			<b>39.17</b>
<b>0.43</b>	<b>0.28</b>			<b>38.89</b>
<b>0.60</b>	<b>0.17</b>		<b>Por Av. Recalde</b>	<b>38.72</b>
<b>1.14</b>	<b>0.54</b>		<b>Por calle Saavedra</b>	<b>38.18</b>

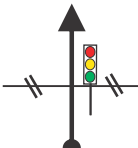
<b>CH 0</b>	<b>Parque de Servicio - Salida</b>	<b>Distancia</b> <b>39.32</b> kms.	<b>Etapa 1</b>	<b>Pag.</b>
<b>CH 1</b>	<b>Banda Sur</b>		<b>Sector 1</b>	<b>2</b>
<b>Nro.</b>	<b>PRUEBA ESPECIAL</b>	<b>Kms.</b>	<b>Promedio</b> <b>52.42</b> kms.	<b>Tiempo Otorgado</b> <b>45'</b>
<b>ENLACE</b>				

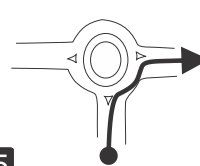
Distancia		Dirección	Información	Distancia Regresiva
Total	Parcial			
<b>1.44</b>	<b>0.30</b>	 <p><b>7</b></p>	<b>Semáforo</b> Por Av. Pte. Castillo  Zona Urbana	<b>37.88</b>
<b>1.97</b>	<b>0.53</b>	 <p><b>8</b></p>	<b>Monumento Felipe Varela</b> Continúa Av. Pte. Castillo	<b>37.35</b>
<b>3.32</b>	<b>1.35</b>	 <p><b>9</b></p>		<b>36.00</b>
<b>3.43</b>	<b>0.11</b>	 <p><b>10</b></p>	<b>Bienvenido</b> <b>Valle Viejo</b>	<b>35.89</b>
<b>3.88</b>	<b>0.45</b>	 <p><b>11</b></p>	<b>Semáforo</b>	<b>35.44</b>
<b>3.96</b>	<b>0.08</b>	 <p><b>12</b></p>	 Zona de Reabastecimiento de Combustible en Estación de Servicio YPF <b>Continúa Av. Pte. Castillo</b> 	<b>35.36</b>







<b>CH 0</b>	<b>Parque de Servicio - Salida</b>	<b>Distancia</b> <b>39.32</b> kms.	<b>Etapas</b> <b>1</b>	<b>Pag.</b> <b>3</b>
<b>CH 1</b>	<b>Banda Sur</b>		<b>Sector 1</b>	
<b>Nro.</b>	<b>PRUEBA ESPECIAL</b>	<b>Kms.</b>	<b>Promedio</b> <b>52.42</b> kms.	<b>Tiempo Otorgado</b> <b>45'</b>
<b>ENLACE</b>				

Distancia		Dirección	Información	Distancia Regresiva
Total	Parcial			
<b>4.15</b>	<b>0.19</b>	 13	<b>Semáforo</b>	<b>35.17</b>
<b>4.68</b>	<b>0.53</b>	 14		<b>34.64</b>
<b>6.00</b>	<b>1.32</b>	 15	<b>Monumento Felipe Varela</b> Continúa por Rp N°1	<b>33.32</b>
<b>6.16</b>	<b>0.16</b>	 16	<div style="border: 1px solid black; padding: 5px; width: fit-content;">           Banda de Varela            Polcos            Las Piquitas         </div>	<b>33.16</b>
<b>6.37</b>	<b>0.21</b>	 17		<b>32.95</b>
<b>7.50</b>	<b>1.13</b>	 18	Continúa por Rp N°1	<b>31.82</b>



<b>CH 0</b>	<b>Parque de Servicio - Salida</b>	<b>Distancia</b> <b>39.32</b> kms.	<b>Etapa 1</b>	<b>Pag.</b>
<b>CH 1</b>	<b>Banda Sur</b>		<b>Sector 1</b>	<b>4</b>
<b>Nro.</b>	<b>PRUEBA ESPECIAL</b>	<b>Kms.</b>	<b>Promedio</b> <b>52.42</b> kms.	<b>Tiempo Otorgado</b> <b>45'</b>
<b>ENLACE</b>				

Distancia		Dirección	Información	Distancia Regresiva						
Total	Parcial									
<b>7.67</b>	<b>0.17</b>		<table border="1"> <tr> <td>Polcos</td> <td>2</td> </tr> <tr> <td>El Desmorte</td> <td>12</td> </tr> <tr> <td>Las Pirquitas</td> <td>18</td> </tr> </table>	Polcos	2	El Desmorte	12	Las Pirquitas	18	<b>31.65</b>
Polcos	2									
El Desmorte	12									
Las Pirquitas	18									
<b>9.37</b>	<b>1.70</b>			<b>29.95</b>						
<b>13.15</b>	<b>3.78</b>			<b>26.17</b>						
<b>14.81</b>	<b>1.66</b>			<b>24.51</b>						
<b>17.32</b>	<b>2.51</b>			<b>22.00</b>						
<b>18.73</b>	<b>1.41</b>			<b>20.59</b>						

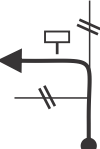
<b>CH 0</b>	<b>Parque de Servicio - Salida</b>	<b>Distancia</b> <b>39.32</b> kms.	<b>Etapas</b> <b>1</b>	<b>Pag.</b> <b>5</b>
<b>CH 1</b>	<b>Banda Sur</b>		<b>Sector 1</b>	
<b>Nro.</b>	<b>PRUEBA ESPECIAL</b>	<b>Kms.</b>	<b>Promedio</b> <b>52.42</b> kms.	<b>Tiempo Otorgado</b> <b>45'</b>
<b>ENLACE</b>				

Distancia		Dirección	Información	Distancia Regresiva
Total	Parcial			
19.20	0.47	 25		20.12
22.15	2.95	 26		17.17
25.15	3.00	 27		14.17
33.05	7.90	 28	<div style="border: 1px solid black; padding: 5px; display: inline-block;"> <b>BIENVENIDOS ISLA LARGA</b> </div> <div style="border: 1px solid black; padding: 2px; font-size: 8px; margin-top: 5px;">           GPS:            S 28 14 173            W 65 45 350            ALT. 802         </div> <div style="border: 1px solid black; padding: 2px; margin-top: 5px;">            Zona de Reabastecimiento de Combustible en SurtiRally         </div>	6.27
38.80	5.75	 29	<div style="border: 1px solid black; padding: 5px; display: inline-block;">           ↑ La Puerta            ← La Puerta (Banda Sud)            ← El Rodeo         </div>	0.52
38.90	0.10	 30	<div style="border: 1px solid black; padding: 5px; display: inline-block;"> <b>Deja Rp N°1</b>   <b>LA BANDA SUD BIENVENIDOS</b> </div>	0.42

<b>CH 0</b>	<b>Parque de Servicio - Salida</b>	<b>Distancia</b> <b>39.32</b> kms.	<b>Etapa 1</b>	<b>Pag.</b>
<b>CH 1</b>	<b>Banda Sur</b>		<b>Sector 1</b>	<b>6</b>
<b>Nro.</b>	<b>PRUEBA ESPECIAL</b>	<b>Kms.</b>	<b>Promedio</b> <b>52.42</b> kms.	<b>Tiempo Otorgado</b> <b>45'</b>
	<b>ENLACE</b>			

Distancia		Dirección	Información	Distancia Regresiva
Total	Parcial			
<b>39.10</b>	<b>0.20</b>	 <b>31</b>		<b>0.22</b>
<b>39.32</b>	<b>0.22</b>	 <b>32</b>	 <b>CH 1</b> En piedras blancas. <div style="border: 1px solid black; padding: 2px; width: fit-content; margin-left: auto;">1er. Auto 09:45 hs.</div>	<b>0.00</b>









LPE	1	Banda Sur	Distancia	Etapa 1	Pag.
CH	2	La Aguada	24.09	Sector 2	7
Nro. PRUEBA ESPECIAL			Kms.	Promedio	Tiempo Otorgado
1/4	Banda Sur La Puerta		7.00	48.18	30'
			kms.	kms.	

Distancia		Dirección	Información	Distancia Regresiva
Total	Parcial			
0.00	0.00	 1 7.00	LPE 1/4 En Árbol con Letra B.	24.09
		 2 6.20	<div style="border: 1px solid black; padding: 2px;">           GPS:            S 28 11 575            W 65 46 498            ALT. 852         </div> <div style="border: 1px solid black; padding: 2px;">           1er. Auto            09:48 hs         </div>	
0.80	0.80	 3 5.92		23.29
1.08	0.28	 4 5.30		23.01
1.70	0.62	 5 4.78		22.39
2.22	0.52	 6 2.93		21.87
4.07	1.85	 6 2.93		20.02

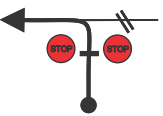
LPE	1	Banda Sur	Distancia	Etapa 1	Pag.
CH	2	La Aguada	24.09	Sector 2	8
Nro. PRUEBA ESPECIAL			Kms.	Promedio	Tiempo Otorgado
1/4	Banda Sur La Puerta		7.00	48.18	30'

Distancia		Dirección	Información	Distancia Regresiva				
Total	Parcial							
4.18	0.11			19.91				
5.65	1.47			18.44				
5.72	0.07			18.37				
5.85	0.13			18.24				
6.55	0.70			17.54				
7.00	0.45		FPE 1/4 En poste de madera con letra B. <table border="1" style="margin-left: auto; margin-right: auto;"> <tr> <td>GPS:</td> </tr> <tr> <td>S 28 11 243</td> </tr> <tr> <td>W 65 46 618</td> </tr> <tr> <td>ALT. 870</td> </tr> </table>	GPS:	S 28 11 243	W 65 46 618	ALT. 870	17.09
GPS:								
S 28 11 243								
W 65 46 618								
ALT. 870								

LPE	1	Banda Sur	Distancia	Etapa 1	Pag.
CH	2	La Aguada	24.09	Sector 2	9
			kms.		
Nro.	PRUEBA ESPECIAL		Kms.	Promedio	Tiempo Otorgado
1/4	Banda Sur La Puerta		7.00	48.18	30'
				kms.	

Distancia		Dirección	Información	Distancia Regresiva
Total	Parcial			
7.05	0.05	 13		17.04
7.12	0.07	 14	 Antes de subir a Rp N°1	16.97
8.15	1.03	 15		15.94
9.90	1.75	 16		14.19
17.45	7.55	 17	COLPES	6.64
24.09	6.64	 18	 <b>CH 2</b> Deja Rp N°1 y CH frente a Cartel deteriorado. <div style="border: 1px solid black; padding: 2px; display: inline-block;">1er. Auto 10:18 hs.</div>	0.00







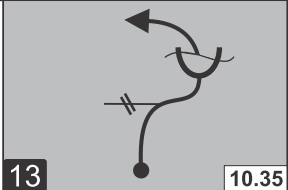
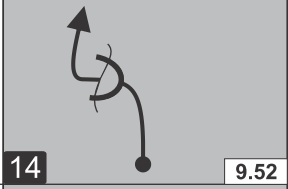
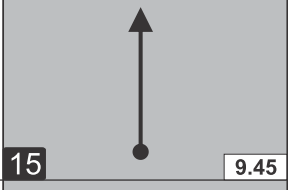

LPE	2	La Aguada	Distancia	Etapa 1	Pag.
CH	3	Rodeo Grande	28.65	Sector 3	10
			kms.		
Nro.	PRUEBA ESPECIAL		Kms.	Promedio	Tiempo Otorgado
2/5	La Aguada Los Varela		19.90	49.11	35'
				kms.	

Distancia		Dirección	Información	Distancia Regresiva
Total	Parcial			
0.00	0.00	<p>1</p> <p>19.90</p>	<b>LPE 2/5</b> En poste de alambrado con letra B roja. 1er. Auto 10:21hs GPS: S 28 02 578 W 65 49 000 ALT. 1066	28.65
0.72	0.72	<p>2</p> <p>19.18</p>		27.93
3.55	2.83	<p>3</p> <p>16.35</p>		25.10
3.81	0.26	<p>4</p> <p>16.09</p>		24.84
3.92	0.11	<p>5</p> <p>15.98</p>		24.73
4.20	0.28	<p>6</p> <p>15.70</p>		24.45

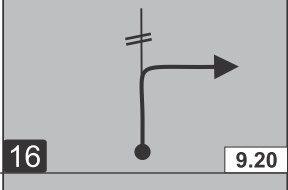



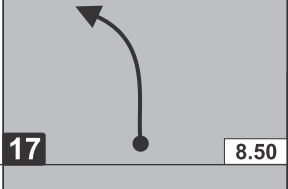



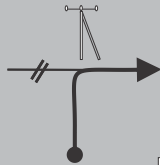

LPE	<b>2</b>	La Aguada	Distancia	<b>28.65</b>	Etapa 1	Pag.
CH	<b>3</b>	Rodeo Grande		kms.	Sector 3	<b>11</b>
Nro.	PRUEBA ESPECIAL		Kms.	Promedio	Tiempo Otorgado	
<b>2/5</b>	La Aguada Los Varela		<b>19.90</b>	<b>49.11</b>	<b>35'</b>	
				kms.		

Distancia		Dirección	Información	Distancia Regresiva
Total	Parcial			
4.33	0.13			24.32
6.66	2.33		<div style="border: 1px solid black; padding: 5px; text-align: center;"> <b>Bienvenidos La Aguada</b> </div>	21.99
6.80	0.14			21.85
7.10	0.30		 Zona Urbana	21.55
7.96	0.86			20.69
9.25	1.29			19.40

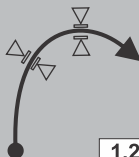

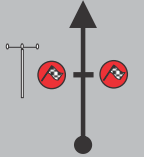

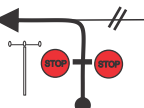



LPE	2	La Aguada	Distancia	Etapa 1	Pag.
CH	3	Rodeo Grande	28.65	Sector 3	12
			kms.		
Nro.	PRUEBA ESPECIAL		Kms.	Promedio	Tiempo Otorgado
2/5	La Aguada Los Varela		19.90	49.11	35'
				kms.	

Distancia		Dirección	Información	Distancia Regresiva
Total	Parcial			
9.55	0.30	 13 10.35		19.10
10.38	0.83	 14 9.52		18.27
10.45	0.07	 15 9.45	 <b>ASFALTO</b>	18.20
10.70	0.25	 16 9.20	 Rescate Médico  Comunicación  GPS: S 27 57 589 W 65 48 762 ALT. 1192	17.95
11.40	0.70	 17 8.50		17.25
11.60	0.20	 18 8.30	 <b>RIO NATURAL</b>	17.05

LPE	<b>2</b>	La Aguada	Distancia	<b>28.65</b>	Etapa 1	Pag.
CH	<b>3</b>	Rodeo Grande	kms.		Sector 3	<b>13</b>
Nro.	PRUEBA ESPECIAL		Kms.	Promedio	Tiempo Otorgado	
<b>2/5</b>	La Aguada Los Varela		<b>19.90</b>	<b>49.11</b>	<b>35'</b>	
				kms.		

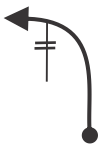
Distancia		Dirección	Información	Distancia Regresiva
Total	Parcial			
12.71	1.11	 19 <span style="float: right;">7.19</span>		15.94
16.11	3.40	 20 <span style="float: right;">3.79</span>		12.54
16.94	0.83	 21 <span style="float: right;">2.96</span>		11.71
18.66	1.72	 22 <span style="float: right;">1.24</span>		9.99
19.90	1.24	 23 <span style="float: right;">0.00</span>	 <b>FPE 2/5</b>  En poste de madera con letra B. GPS: S 27 55 391 W 65 51 762 ALT. 1184	8.75
20.30	0.40	 24	 En poste de madera con letra M. Continúa por Rp N°1.	8.35

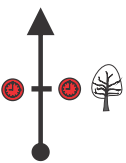
LPE	2	La Aguada	Distancia	Etapa 1	Pag.
CH	3	Rodeo Grande	28.65	Sector 3	14
			kms.		
Nro.	PRUEBA ESPECIAL		Kms.	Promedio	Tiempo Otorgado
2/5	La Aguada Los Varela		19.90	49.11	35'
				kms.	









Distancia		Dirección	Información	Distancia Regresiva
Total	Parcial			
22.77	2.47	 25	<div style="border: 1px solid black; padding: 5px; display: inline-block;">El Potrerillo</div>	5.88
23.26	0.49	 26	<div style="border: 1px solid black; padding: 5px; display: inline-block;">           ↑ Los Talas 1            ↑ La Puerta 27            ↑ Catamarca 73         </div>	5.39
23.70	0.44	 27	 Zona de Reabastecimiento de Combustible en Estación de Servicio YPF  <div style="border: 1px solid black; padding: 2px; display: inline-block;">           GPS:            S 27 56 966            W 65 51 867            ALT. 1165         </div>	4.95
24.35	0.65	 28	 A la Izquierda STOP P.E. N° 3/6	4.30
28.56	4.21	 29	Deja Rp N° 1	0.09
28.65	0.09	 30	 <b>CH 3</b> En Árbol con letra M.  <div style="border: 1px solid black; padding: 2px; display: inline-block;">1er. Auto 10:56 hs.</div>	0.00





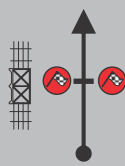

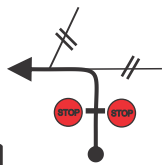

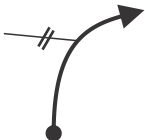

LPE	<b>3</b>	Rodeo Grande	Distancia		Etapa 1	Pag.
CH	<b>3A</b>	Flexi Service - Ingreso	<b>73.72</b>		Sector 4	<b>15</b>
			kms.			
Nro.	PRUEBA ESPECIAL		Kms.	Promedio	Tiempo Otorgado	
<b>3/6</b>	Rodeo Grande Los Talas		<b>8.68</b>	<b>73.72</b>	<b>1:00'</b>	
				kms.		

Distancia		Dirección	Información	Distancia Regresiva
Total	Parcial			
0.00	0.00	 1 8.68	<b>LPE 3/6</b> En Árbol con Letra B. GPS: S 27 59 099 W 65 50 420 ALT. 1115 1er. Auto 10:59 hs	73.72
0.94	0.94	 2 7.74	 RIO NATURAL	72.78
2.25	1.31	 3 6.43		71.47
3.70	1.45	 4 4.98		70.02
4.50	0.80	 5 4.18		69.22
4.60	0.10	 6 4.08		69.12









LPE	<b>3</b>	Rodeo Grande	Distancia	<b>73.72</b>	Etapa 1	Pag.
CH	<b>3A</b>	Flexi Service - Ingreso		kms.	Sector 4	<b>16</b>
Nro.	PRUEBA ESPECIAL		Kms.	Promedio	Tiempo Otorgado	
<b>3/6</b>	Rodeo Grande Los Talas		<b>8.68</b>	<b>73.72</b> kms.	<b>1:00'</b>	

Distancia		Dirección	Información	Distancia Regresiva
Total	Parcial			
6.07	1.47	 <b>7</b> <span style="float: right;">2.61</span>		67.65
7.78	1.71	 <b>8</b> <span style="float: right;">0.90</span>		65.94
8.09	0.31	 <b>9</b> <span style="float: right;">0.59</span>		65.63
8.25	0.16	 <b>10</b> <span style="float: right;">0.43</span>		65.47
8.68	0.43	 <b>11</b> <span style="float: right;">0.00</span>	 <b>FPE 3/6</b> En poste de tranquera con letra B. <div style="border: 1px solid black; padding: 2px; width: fit-content;">             GPS:              S 27 57 252              W 65 51 782              ALT. 1171           </div>	65.04
8.91	0.23	 <b>12</b>	 Antes de Continuar por Rp N°1.	64.81

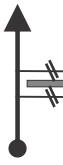



LPE	<b>3</b>	Rodeo Grande	Distancia	<b>73.72</b>	Etapa 1	Pag.
CH	<b>3A</b>	Flexi Service - Ingreso		<b>73.72</b> kms.	Sector 4	<b>17</b>
Nro.	PRUEBA ESPECIAL		Kms.	Promedio	Tiempo Otorgado	
<b>3/6</b>	Rodeo Grande Los Talas		<b>8.68</b>	<b>73.72</b> kms.	<b>1:00'</b>	

Distancia		Dirección	Información	Distancia Regresiva
Total	Parcial			
<b>13.10</b>	<b>4.19</b>	 13	 A la izquierda LPE N°3/6	<b>60.62</b>
<b>19.69</b>	<b>6.59</b>	 14	Badén de Cemento	<b>54.03</b>
<b>20.70</b>	<b>1.01</b>	 15	Villa de Colpes →  A la izquierda LPE N°2/5	<b>53.02</b>
<b>30.24</b>	<b>9.54</b>	 16		<b>43.48</b>
<b>34.79</b>	<b>4.55</b>	 17		<b>38.93</b>
<b>36.56</b>	<b>1.77</b>	 18	La Puerta →	<b>37.16</b>



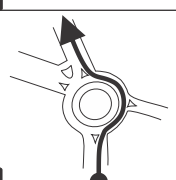
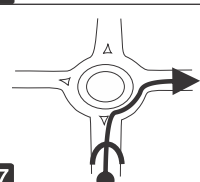

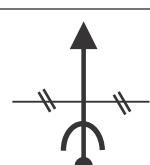
LPE	<b>3</b>	Rodeo Grande	Distancia	Etapa 1	Pag.
CH	<b>3A</b>	Flexi Service - Ingreso	<b>73.72</b> kms.	Sector 4	<b>18</b>
Nro.	PRUEBA ESPECIAL		Kms.	Promedio	Tiempo Otorgado
<b>3/6</b>	Rodeo Grande Los Talas		<b>8.68</b>	<b>73.72</b> kms.	<b>1:00'</b>

Distancia		Dirección	Información	Distancia Regresiva
Total	Parcial			
37.65	1.09	 19	 A la Derecha STOP P.E. N° 1/4	36.07
38.48	0.83	 20	 A la Derecha ingreso a L.P.E. N° 1/4	35.24
52.20	13.72	 21	<div style="border: 1px solid black; padding: 2px; display: inline-block;">           Villa → Las Pirquitas         </div>	21.52
58.08	5.88	 22		15.64
58.70	0.62	 23		15.02
64.20	5.50	 24		9.52

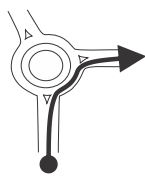

LPE	<b>3</b>	Rodeo Grande	Distancia	<b>73.72</b>	Etapa 1	Pag.
CH	<b>3A</b>	Flexi Service - Ingreso		kms.	Sector 4	<b>19</b>
Nro.	PRUEBA ESPECIAL		Kms.	Promedio	Tiempo Otorgado	
<b>3/6</b>	Rodeo Grande Los Talas		<b>8.68</b>	<b>73.72</b>	<b>1:00'</b>	
				kms.		

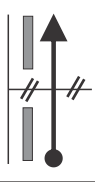
Distancia		Dirección	Información	Distancia Regresiva
Total	Parcial			
<b>68.65</b>	<b>4.45</b>	 25		<b>5.07</b>
<b>69.80</b>	<b>1.15</b>	 26	Continúa por Rp N°1	<b>3.92</b>
<b>71.36</b>	<b>1.56</b>	 27	Monumento Felipe Varela Continúa por calle RECALDE	<b>2.36</b>
<b>71.58</b>	<b>0.22</b>	 28		<b>2.14</b>
<b>71.96</b>	<b>0.38</b>	 29		<b>1.76</b>
<b>72.19</b>	<b>0.23</b>	 30		<b>1.53</b>

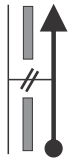
LPE	<b>3</b>	Rodeo Grande	Distancia	<b>73.72</b>	Etapa 1	Pag.
CH	<b>3A</b>	Flexi Service - Ingreso	kms.		Sector 4	<b>20</b>
Nro.	PRUEBA ESPECIAL		Kms.	Promedio	Tiempo Otorgado	
<b>3/6</b>	Rodeo Grande Los Talas		<b>8.68</b>	<b>73.72</b> kms.	<b>1:00'</b>	

Distancia		Dirección	Información	Distancia Regresiva
Total	Parcial			
72.68	0.49	 31		1.04
72.80	0.12	 32		0.92
73.10	0.30	 33		0.62
73.40	0.30	 34		0.32
73.49	0.09	 35		0.23
73.59	0.10	 36		0.13

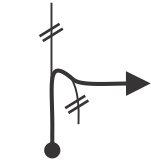
LPE	<b>3</b>	Rodeo Grande	Distancia	Etapa 1	Pag.
CH	<b>3A</b>	Flexi Service - Ingreso	<b>73.72</b> kms.	Sector 4	<b>21</b>
Nro.	PRUEBA ESPECIAL		Kms.	Promedio	Tiempo Otorgado
<b>3/6</b>	Rodeo Grande Los Talas		<b>8.68</b>	<b>73.72</b> kms.	<b>1:00'</b>

Distancia		Dirección	Información	Distancia Regresiva
Total	Parcial			
<b>73.66</b>	<b>0.07</b>	 <p><b>37</b></p>		<b>0.06</b>
<b>73.72</b>	<b>0.06</b>	 <p><b>38</b></p>	 <p><b>CH 3A</b> Ingreso - Flexi Service Predio Ferial Catamarca PORTON N°7</p> <div style="border: 1px solid black; padding: 2px;"> <p>GPS: S 28 26 891 W 65 45 338 ALT. 533</p> </div>	<b>0.00</b>

<b>CH</b>	<b>3D</b>	Parque de Servicio - Salida		Distancia	<b>39.32</b>	<i>Etapa 1</i>	<i>Pag.</i>
<b>CH</b>	<b>4</b>	Banda Sur			kms.	<i>Sector 7</i>	<b>22</b>
<b>Nro.</b>	<b>PRUEBA ESPECIAL</b>		<b>Kms.</b>	<b>Promedio</b>	<b>52.42</b>	<b>Tiempo Otorgado</b>	
	<b>ENLACE</b>				kms.	<b>45'</b>	

Se repite ídem a páginas 1, 2, 3, 4, 5 y 6.

<b>LPE</b>	<b>4</b>	Banda Sur		Distancia	<b>24.09</b>	<i>Etapa 1</i>	<i>Pag.</i>
<b>CH</b>	<b>5</b>	La Aguada			kms.	<i>Sector 8</i>	
<b>Nro.</b>	<b>PRUEBA ESPECIAL</b>		<b>Kms.</b>	<b>Promedio</b>	<b>48.18</b>	<b>Tiempo Otorgado</b>	
<b>1/4</b>	Banda Sur La Puerta		<b>7.00</b>		kms.	<b>30'</b>	

Se repite ídem a páginas 7, 8 y 9.

<b>LPE</b>	<b>5</b>	La Aguada		Distancia	<b>28.65</b>	<i>Etapa 1</i>	<i>Pag.</i>
<b>CH</b>	<b>6</b>	Rodeo Grande			kms.	<i>Sector 9</i>	
<b>Nro.</b>	<b>PRUEBA ESPECIAL</b>		<b>Kms.</b>	<b>Promedio</b>	<b>49.11</b>	<b>Tiempo Otorgado</b>	
<b>2/5</b>	La Aguada Los Varela		<b>19.90</b>		kms.	<b>35'</b>	



Se repite ídem a páginas 10, 11, 12, 13 y 14.

<b>LPE</b>	<b>6</b>	Rodeo Grande		Distancia	<b>75.03</b>	<i>Etapa 1</i>	<i>Pag.</i>
<b>CH</b>	<b>7</b>	Super Especial			kms.	<i>Sector 10</i>	
<b>Nro.</b>	<b>PRUEBA ESPECIAL</b>		<b>Kms.</b>	<b>Promedio</b>	<b>75.03</b>	<b>Tiempo Otorgado</b>	
<b>3/6</b>	Rodeo Grande Los Talas		<b>8.68</b>		kms.	<b>1:00'</b>	

Se repite ídem a páginas 15, 16, 17, 18, 19 y 20 (hasta figura 34 ).

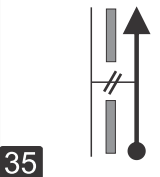
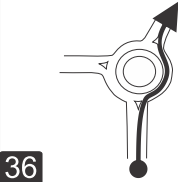
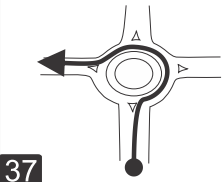
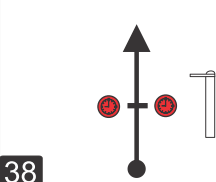

LPE	6	Rodeo Grande	Distancia	Etapa 1	Pag.
CH	7	Super Especial	75.03	Sector 10	23
			kms.		
Nro.	PRUEBA ESPECIAL		Kms.	Promedio	Tiempo Otorgado
3/6	Rodeo Grande Los Talas		8.68	75.03	1:00'
				kms.	

Distancia		Dirección	Información	Distancia Regresiva
Total	Parcial			
73.49	0.09			1.54
73.71	0.22			1.32
74.08	0.37		Por Av. Arnaldo Castillo	0.95
75.03	0.95		 <b>CH 7</b> En poste de Cemento con letra M. <div style="border: 1px solid black; padding: 2px; width: fit-content; margin-left: auto;">1er. Auto 16:23 hs.</div>	0.00







LPE	<b>7</b>	Catamarca	Distancia	Etapa 1	Pag.
CH	<b>7A</b>	Zona Técnica - Ingreso	<b>3.68</b> kms.	Sector 11	<b>24</b>
Nro.	PRUEBA ESPECIAL		Kms.	Promedio	Tiempo Otorgado
<b>7</b>	Super Especial CATAMARCA		<b>2.40</b>	<b>22.08</b> kms.	<b>10'</b>

Distancia		Dirección	Información	Distancia Regresiva
Total	Parcial			
0.00	0.00	<p><b>1</b> <span style="float: right;">2.40</span></p>	<b>LPE 7</b> <p>En poste con Letra B.</p> <div style="border: 1px solid black; padding: 2px;"> GPS:  S 28 27 155  W 65 45 934  ALT. 524 </div> <div style="border: 1px solid black; padding: 2px; margin-top: 5px;"> 1er. Auto  16:26 hs </div>	<b>3.68</b>
0.05	0.05	<p><b>2</b> <span style="float: right;">2.35</span></p>		<b>3.63</b>
0.62	0.57	<p><b>3</b> <span style="float: right;">1.78</span></p>	Vuelve por Av. Castillo	<b>3.06</b>
1.10	0.48	<p><b>4</b> <span style="float: right;">1.30</span></p>		<b>2.58</b>
1.28	0.18	<p><b>5</b> <span style="float: right;">1.12</span></p>	POR CANAL	<b>2.40</b>
1.45	0.17	<p><b>6</b> <span style="float: right;">0.95</span></p>		<b>2.23</b>

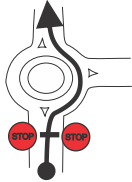
LPE	<b>7</b>	Catamarca	Distancia	Etapa 1	Pag.
CH	<b>7A</b>	Zona Técnica - Ingreso	<b>3.68</b> kms.	Sector 11	<b>25</b>
Nro.	PRUEBA ESPECIAL		Kms.	Promedio	Tiempo Otorgado
<b>7</b>	Super Especial CATAMARCA		<b>2.40</b>	<b>22.08</b> kms.	<b>10'</b>

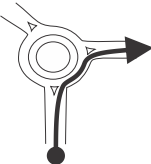
Distancia		Dirección	Información	Distancia Regresiva
Total	Parcial			
1.65	0.20		Deja Canal	2.03
1.80	0.15			1.88
2.00	0.20			1.68
2.20	0.20			1.48
2.25	0.05			1.43
2.40	0.15		<b>FPE 7</b> En poste de iluminarias con letra B. <div style="border: 1px solid black; padding: 2px; width: fit-content;">             GPS:              S 28 27 130              W 65 45 738              ALT. 525           </div>	<b>1.28</b>

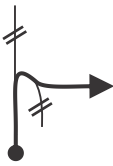
LPE	7	Catamarca	Distancia	Etapa 1	Pag.
CH	7A	Zona Técnica - Ingreso	3.68	Sector 11	26
			kms.		
Nro.	PRUEBA ESPECIAL		Kms.	Promedio	Tiempo Otorgado
7	Super Especial CATAMARCA		2.40	22.08	10'
				kms.	

Distancia		Dirección	Información	Distancia Regresiva
Total	Parcial			
2.68	0.28	 <p>13</p>	 En Cartel de Seda el Paso	1.00
3.20	0.52	 <p>14</p>		0.48
3.45	0.25	 <p>15</p>		0.23
3.55	0.10	 <p>16</p>		0.13
3.62	0.07	 <p>17</p>		0.06
3.68	0.06	 <p>18</p>	 <b>CH 7a</b> Ingreso - Zona Técnica Predio Ferial Catamarca PORTON N°7 GPS: S 28 26 891 W 65 45 338 ALT. 533	0.00



**Día 2- Sección 3**







**Etapas 2**

**25 de Junio del 2017**

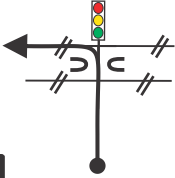

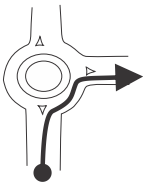

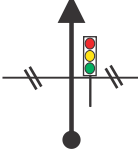
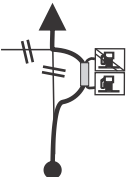

CH 7F	Parque de Servicio - Salida	Distancia	Etapa 2	Pag.
CH 8	El Portezuelo	13.38	Sector 16	27
		kms.		
Nro.	PRUEBA ESPECIAL	Kms.	Promedio	Tiempo Otorgado
<b>ENLACE</b>			40.14	20'
			kms.	

Distancia		Dirección	Información	Distancia Regresiva
Total	Parcial			
0.00	0.00	<p>1</p>	<p><b>CH 7F</b></p> <p>Salida Parque de Servicio Predio Ferial Catamarca Portón 6</p> <p>GPS: S 28 26 922 W 65 45 321 ALT. 531</p>	13.38
0.10	0.10	<p>2</p>		13.28
0.15	0.05	<p>3</p>		13.23
0.43	0.28	<p>4</p>		12.95
0.60	0.17	<p>5</p>	Por Av. Recalde	12.78
1.14	0.54	<p>6</p>	Por calle Saavedra	12.24

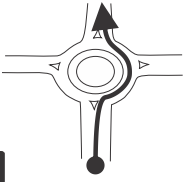
CH 7F	Parque de Servicio - Salida	Distancia	Etapa 2	Pag.
CH 8	El Portezuelo	13.38	Sector 16	28
Nro.	PRUEBA ESPECIAL	Kms.	Promedio	Tiempo Otorgado
	<b>ENLACE</b>		40.14	20'
			kms.	kms.



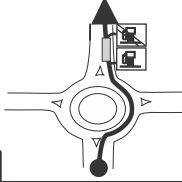

Distancia		Dirección	Información	Distancia Regresiva
Total	Parcial			
1.44	0.30	 <p>7</p>	<b>Semáforo</b> Por Av. Pte. Castillo 	11.94
1.97	0.53	 <p>8</p>	<b>Monumento Felipe Varela</b> Continúa Av. Pte. Castillo	11.41
3.32	1.35	 <p>9</p>		10.06
3.43	0.11	 <p>10</p>	<div style="border: 1px solid black; padding: 5px; display: inline-block;"> <b>Bienvenido</b>  <b>Valle Viejo</b> </div>	9.95
3.88	0.45	 <p>11</p>	<b>Semáforo</b>	9.50
3.96	0.08	 <p>12</p>	 Zona de Reabastecimiento de Combustible en Estación de Servicio YPF  <b>Continúa Av. Pte. Castillo</b>  <div style="border: 1px solid black; padding: 2px; display: inline-block;">             GPS:              S 28 26 960              W 65 46 380              ALT. 528           </div>	9.42

CH	7F	Parque de Servicio - Salida	Distancia	Etapa 2	Pag.
CH	8	El Portezuelo	13.38	Sector 16	29
Nro.		PRUEBA ESPECIAL	Kms.	Promedio	Tiempo Otorgado
		<b>ENLACE</b>		40.14	20'
				kms.	

Distancia		Dirección	Información	Distancia Regresiva
Total	Parcial			
4.12	0.16	 13		9.26
6.15	2.03	 14		7.23
6.76	0.61	 15		6.62
6.98	0.22	 16	<div style="border: 1px solid black; padding: 5px; width: fit-content;"> <ul style="list-style-type: none"> <li>↑ Portezuelo</li> <li>↑ La Merced</li> <li>↑ Tucumán</li> </ul> </div>	6.40
7.10	0.12	 17	<div style="border: 1px solid black; padding: 5px; width: fit-content;">  Zona de Reabastecimiento de Combustible en SURTIRALLY         </div> <div style="border: 1px solid black; padding: 5px; width: fit-content; margin-top: 10px;">           GPS:            S 28 28 099            W 65 41 703            ALT. 601         </div>	6.28
7.70	0.60	 18		5.68

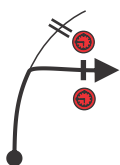

CH	7F	Parque de Servicio - Salida	Distancia	Etapa 2	Pag.
CH	8	El Portezuelo	13.38	Sector 16	30
Nro.		PRUEBA ESPECIAL	Kms.	Promedio	Tiempo Otorgado
		<b>ENLACE</b>		40.14	20'
				kms.	kms.

Distancia		Dirección	Información	Distancia Regresiva
Total	Parcial			
9.09	1.39	 19	<div style="border: 1px solid black; padding: 5px; width: fit-content;">           ↑ La Merced 33            ↑ Sgo. del Estero 196            ↑ Tucumán 215         </div> Control Policial	4.29
13.20	4.11	 20	<div style="border: 1px solid black; padding: 5px; width: fit-content;">           Portezuelo         </div>	0.18
13.38	0.18	 21	 <b>CH 8</b> Deja RN N° 38. CH antes de tierra. <div style="border: 1px solid black; padding: 2px; width: fit-content; margin-top: 5px;">             1er. Auto              08:45 hs.           </div>	0.00







LPE	8	El Portezuelo	Distancia	Etapa 2	Pag.
CH	9	San Pedro	72.15	Sector 17	31
			kms.		
Nro.	PRUEBA ESPECIAL		Kms.	Promedio	Tiempo Otorgado
8/12	El Portezuelo Ruta 33		12.00	72.15	1:00'
				kms.	

Distancia		Dirección	Información	Distancia Regresiva
Total	Parcial			
0.00	0.00		<b>LPE 8/12</b> En ramas de Árbol con rojo. GPS: S 28 28 952 W 65 38 849 ALT. 605 1er. Auto 08:48 hs	72.15
1.98	1.98		 <b>Angosto</b>	70.17
2.79	0.81		 <b>Angosto</b>	69.36
4.55	1.76			67.60
5.00	0.45			67.15
5.20	0.20			66.95

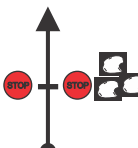

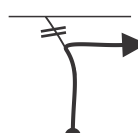

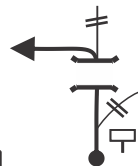
LPE	8	El Portezuelo	Distancia	Etapa 2	Pag.
CH	9	San Pedro	72.15	Sector 17	32
			kms.		
Nro.	PRUEBA ESPECIAL		Kms.	Promedio	Tiempo Otorgado
8/12	El Portezuelo Ruta 33		12.00	72.15	1:00'
				kms.	

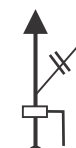
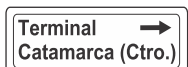
Distancia		Dirección	Información	Distancia Regresiva
Total	Parcial			
5.69	0.49			66.46
5.98	0.29		Por Tierra	66.17
6.78	0.80			65.37
8.72	1.94			63.43
10.98	2.26			61.17
12.00	1.02		FPE 8/12 En olivo con Letra B.	60.15
			GPS: S 28 31 722 W 65 43 658 ALT. 518	





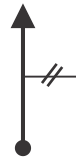

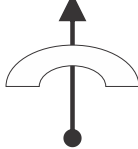
LPE	8	El Portezuelo	Distancia	Etapa 2	Pag.
CH	9	San Pedro	72.15	Sector 17	33
			kms.		
Nro.	PRUEBA ESPECIAL		Kms.	Promedio	Tiempo Otorgado
8/12	El Portezuelo Ruta 33		12.00	72.15	1:00'
				kms.	

Distancia		Dirección	Información	Distancia Regresiva
Total	Parcial			
12.48	0.48	 13	 En piedras con Letra M.	59.67
12.95	0.47	 14	Por desvío.	59.20
13.20	0.25	 15		58.95
16.67	3.47	 16		55.48
18.45	1.78	 17	 Continúa por Circunvalación.	53.70
20.77	2.32	 18		51.38

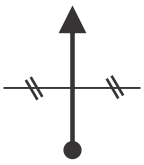

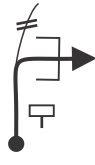





LPE	8	El Portezuelo	Distancia	Etapa 2	Pag.
CH	9	San Pedro	72.15	Sector 17	34
PRUEBA ESPECIAL			Kms.	Promedio	Tiempo Otorgado
Nro.	8/12	El Portezuelo Ruta 33	12.00	72.15 kms.	1:00'

Distancia		Dirección	Información	Distancia Regresiva
Total	Parcial			
23.60	2.83	 19		48.55
24.15	0.55	 20		48.00
25.24	1.09	 21	<div style="border: 1px solid black; padding: 5px; width: fit-content;"> <ul style="list-style-type: none"> <li>↑ Chumbicha</li> <li>↑ La Rioja</li> <li>↑ Belén</li> </ul> </div>	46.91
26.29	1.05	 22	 A la derecha LPE N° 11/13	45.86
28.40	2.11	 23		43.75
32.10	3.70	 24	Control Policial	40.05

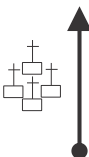
LPE	8	El Portezuelo	Distancia	Etapa 2	Pag.
CH	9	San Pedro	72.15	Sector 17	35
			kms.		
Nro.	PRUEBA ESPECIAL		Kms.	Promedio	Tiempo Otorgado
8/12	El Portezuelo Ruta 33		12.00	72.15	1:00'
				kms.	

Distancia		Dirección	Información	Distancia Regresiva
Total	Parcial			
34.96	2.86	 25		37.19
40.10	5.14	 26		32.05
56.75	16.65	 27	<div style="border: 1px solid black; padding: 5px; width: fit-content;"> <p>↑ Chumbicha  Huillapina →  Concepción →</p> </div>	15.40
65.90	9.15	 28	<div style="border: 1px solid black; padding: 5px; width: fit-content;"> <p>Capayan</p> <p>Deja Rn N°38</p> </div>	6.25
66.04	0.14	 29		6.11
67.45	1.41	 30	<div style="border: 1px solid black; padding: 5px; width: fit-content;"> <p> Zona de Reabastecimiento de Combustible en SURTIRALLY</p> </div> <div style="border: 1px solid black; padding: 5px; width: fit-content; margin-top: 10px;"> <p>GPS:  S 28 45 621  W 66 03 046  ALT. 538</p> </div>	4.70

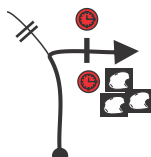
LPE	8	El Portezuelo	Distancia	Etapa 2	Pag.
CH	9	San Pedro	72.15	Sector 17	36
			kms.		
Nro.	PRUEBA ESPECIAL		Kms.	Promedio	Tiempo Otorgado
8/12	El Portezuelo Ruta 33		12.00	72.15	1:00'
				kms.	



Distancia		Dirección	Información	Distancia Regresiva
Total	Parcial			
67.50	0.05	 31	 A la derecha sale Enlace para segunda pasada.	4.65
67.75	0.25	 32		4.40
68.53	0.78	 33		3.62
69.00	0.47	 34	 Zona de Badenes Pronunciados	3.15
71.39	2.39	 35		0.76
72.15	0.76	 36	 CH 9 En Piedras con Letra M.	0.00
			<div style="border: 1px solid black; padding: 2px; display: inline-block;">1er. Auto 09:48 hs.</div>	

LPE	<b>9</b>	San Pedro	Distancia	<b>8.85</b>	Etapa 2	Pag.
CH	<b>9a</b>	Reagrupamiento - Ingreso	kms.		Sector 18	<b>37</b>
Nro.	PRUEBA ESPECIAL		Kms.	Promedio	Tiempo Otorgado	
<b>9/10</b>	San Pedro Concepción		<b>8.60</b>	<b>53.40</b>	<b>10'</b>	
			kms.	kms.		





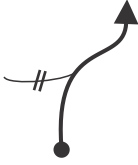
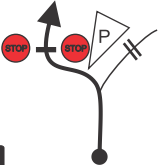

Distancia		Dirección	Información	Distancia Regresiva
Total	Parcial			
0.00	0.00	<p><b>1</b> <span style="float: right;">8.60</span></p>	<b>LPE 9/10</b> En Árbol con letra B. GPS: S 28 44 986 W 66 05 640 ALT. 541 1er. Auto 09:51 hs	<b>8.85</b>
6.25	6.25	<p><b>2</b> <span style="float: right;">2.35</span></p>	<div style="border: 1px solid black; padding: 5px; width: fit-content; margin: auto;">             Bienvenidos a              Concepción           </div>	<b>2.60</b>
6.39	0.14	<p><b>3</b> <span style="float: right;">2.21</span></p>		<b>2.46</b>
7.35	0.96	<p><b>4</b> <span style="float: right;">1.25</span></p>		<b>1.50</b>
8.36	1.01	<p><b>5</b> <span style="float: right;">0.24</span></p>		<b>0.49</b>
8.60	0.24	<p><b>6</b> <span style="float: right;">0.00</span></p>	<b>FPE 9/10</b> En piedras con letra B. GPS: S 28 41 181 W 66 04 117 ALT. 584	<b>0.25</b>



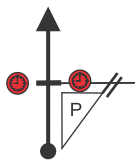

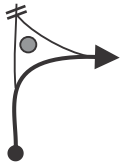

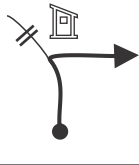
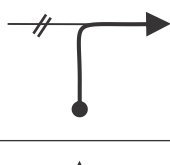

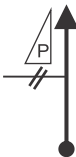

LPE	<b>9</b>	San Pedro	Distancia	<b>8.85</b>	Etapa 2	Pag.
CH	<b>9a</b>	Reagrupamiento - Ingreso	kms.		Sector 18	<b>38</b>
Nro.	PRUEBA ESPECIAL		Kms.	Promedio	Tiempo Otorgado	
<b>9/10</b>	San Pedro Concepción		<b>8.60</b>	<b>53.40</b>	<b>10'</b>	
			kms.	kms.		

Distancia		Dirección	Información	Distancia Regresiva
Total	Parcial			
<b>8.77</b>	<b>0.17</b>			<b>0.08</b>
<b>8.85</b>	<b>0.08</b>		 En Árbol de Plaza con letra M.  <b>CH 9A</b> En Árbol de Plaza con letra M.	<b>0.00</b>

<b>CH 9B</b>	<b>Concepción</b>	<b>Distancia</b> <b>14.75</b> kms.	<b>Etapas</b>	<b>Pag.</b> <b>39</b>
<b>CH 10</b>	<b>San Pedro</b>		<b>Sector 19</b>	
<b>Nro.</b>	<b>PRUEBA ESPECIAL</b>	<b>Kms.</b>	<b>Promedio</b> <b>44.25</b> kms.	<b>Tiempo Otorgado</b> <b>20'</b>
<b>ENLACE</b>				

Distancia		Dirección	Información	Distancia Regresiva
Total	Parcial			
0.00	0.00	 1	 <b>CH 9B</b> En Árbol con letra M.	14.75
0.15	0.15	 2		14.60
3.37	3.22	 3	Zona Urbana	11.38
4.08	0.71	 4		10.67
10.35	6.27	 5		4.40
10.85	0.50	 6		3.90

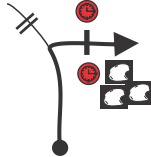





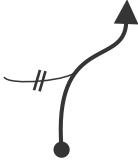
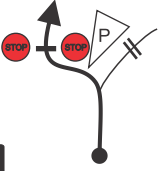

<b>CH 9B</b>	<b>Concepción</b>	<b>Distancia</b> <b>14.75</b> kms.	<b>Etapas</b>	<b>Pag.</b> <b>40</b>
<b>CH 10</b>	<b>San Pedro</b>		<b>Sector 19</b>	
<b>Nro.</b>	<b>PRUEBA ESPECIAL</b>	<b>Kms.</b>	<b>Promedio</b> <b>44.25</b> kms.	<b>Tiempo Otorgado</b> <b>20'</b>
	<b>ENLACE</b>			

Distancia		Dirección	Información	Distancia Regresiva
Total	Parcial			
<b>11.03</b>	<b>0.18</b>	<div style="text-align: center;">  <p><b>7</b></p> </div>		<b>3.72</b>
<b>11.10</b>	<b>0.07</b>	<div style="text-align: center;">  <p><b>8</b></p> </div>		<b>3.65</b>
<b>11.35</b>	<b>0.25</b>	<div style="text-align: center;">  <p><b>9</b></p> </div>		<b>3.40</b>
<b>12.60</b>	<b>1.25</b>	<div style="text-align: center;">  <p><b>10</b></p> </div>	 <b>Zona de Badenes Pronunciados</b>	<b>2.15</b>
<b>13.99</b>	<b>1.39</b>	<div style="text-align: center;">  <p><b>11</b></p> </div>		<b>0.76</b>
<b>14.75</b>	<b>0.76</b>	<div style="text-align: center;">  <p><b>12</b></p> </div>	 <p><b>CH 10</b> En Piedras con Letra M.</p>	<b>0.00</b>
			<div style="border: 1px solid black; padding: 2px; font-size: small;">1er. Auto 09:48 hs.</div>	

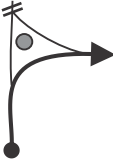







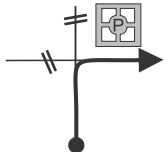

LPE	10	San Pedro	Distancia	Etapa 2	Pag.
CH	11	La Cantera	51.45	Sector 20	41
			kms.		
Nro.	PRUEBA ESPECIAL		Kms.	Promedio	Tiempo Otorgado
10	San Pedro Concepción		8.60	61.74	50'
			kms.		

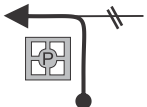
Distancia		Dirección	Información	Distancia Regresiva
Total	Parcial			
0.00	0.00	<p>1</p> <p>8.60</p>	<p><b>LPE 9/10</b></p> <p>En Árbol con letra B.</p> <p>GPS: S 28 44 986 W 66 05 640 ALT. 541</p> <p>1er. Auto 09:51 hs</p>	51.45
6.25	6.25	<p>2</p> <p>2.35</p>	<p>Bienvenidos a Concepción</p>	45.20
6.39	0.14	<p>3</p> <p>2.21</p>		45.06
7.35	0.96	<p>4</p> <p>1.25</p>		44.10
8.36	1.01	<p>5</p> <p>0.24</p>		43.09
8.60	0.24	<p>6</p> <p>0.00</p>	<p><b>FPE 9/10</b></p> <p>En piedras con letra B.</p> <p>GPS: S 28 41 181 W 66 04 117 ALT. 584</p>	42.85

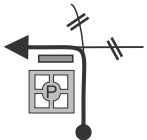

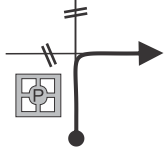

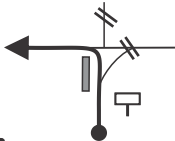

<b>LPE</b>	<b>10</b>	<b>San Pedro</b>	<b>Distancia</b>	<b>Etapa 2</b>	<b>Pag.</b>
<b>CH</b>	<b>11</b>	<b>La Cantera</b>	<b>51.45</b>	<b>Sector 20</b>	<b>42</b>
			<small>kms.</small>		
<b>Nro.</b>	<b>PRUEBA ESPECIAL</b>		<b>Kms.</b>	<b>Promedio</b>	<b>Tiempo Otorgado</b>
<b>10</b>	<b>San Pedro Concepción</b>		<b>8.60</b>	<b>61.74</b>	<b>50'</b>
			<small>kms.</small>	<small>kms.</small>	

Distancia		Dirección	Información	Distancia Regresiva
Total	Parcial			
<b>8.77</b>	<b>0.17</b>			<b>42.68</b>
<b>8.85</b>	<b>0.08</b>		 En Árbol de Plaza con letra M.	<b>42.60</b>
<b>9.05</b>	<b>0.20</b>			<b>42.40</b>
<b>12.27</b>	<b>3.22</b>			<b>39.18</b>
<b>12.98</b>	<b>0.71</b>			<b>38.47</b>
<b>13.79</b>	<b>0.81</b>			<b>37.66</b>

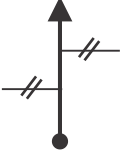
LPE	10	San Pedro	Distancia	Etapa 2	Pag.
CH	11	La Cantera	51.45	Sector 20	43
PRUEBA ESPECIAL			Kms.	Promedio	Tiempo Otorgado
Nro.	10	San Pedro Concepción	8.60	61.74	50'
			kms.	kms.	

Distancia		Dirección	Información	Distancia Regresiva
Total	Parcial			
14.05	0.26	 13		37.40
19.25	5.20	 14	 Zona Urbana	32.20
19.30	0.05	 15	 Zona Urbana	32.15
19.40	0.10	 16	 Zona Urbana	32.05
19.50	0.10	 17	 Zona Urbana	31.95
20.85	1.35	 18	<div style="border: 1px solid black; padding: 5px; display: inline-block;">           Chumbicha →            ← Coneta            ← Catamarca         </div> Por Rn N°38 	30.60

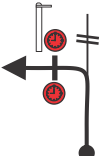
<b>LPE</b>	<b>10</b>	<b>San Pedro</b>	<b>Distancia</b>	<b>Etapa 2</b>	<b>Pag.</b>
<b>CH</b>	<b>11</b>	<b>La Cantera</b>	<b>51.45</b>	<b>Sector 20</b>	<b>44</b>
			<small>kms.</small>		
<b>Nro.</b>	<b>PRUEBA ESPECIAL</b>		<b>Kms.</b>	<b>Promedio</b>	<b>Tiempo Otorgado</b>
<b>10</b>	<b>San Pedro Concepción</b>		<b>8.60</b>	<b>61.74</b>	<b>50'</b>
			<small>kms.</small>	<small>kms.</small>	







Distancia		Dirección	Información	Distancia Regresiva
Total	Parcial			
<b>33.10</b>	<b>12.25</b>	 <b>19</b>	<b>Colonia del Valle</b>	<b>18.35</b>
<b>37.50</b>	<b>4.40</b>	 <b>20</b>		<b>13.95</b>
<b>44.62</b>	<b>7.12</b>	 <b>21</b>	<b>Nueva Coneta</b>	<b>6.83</b>
<b>45.57</b>	<b>0.95</b>	 <b>22</b>	<b>Control Policial</b>	<b>5.88</b>
<b>49.20</b>	<b>3.63</b>	 <b>23</b>		<b>2.25</b>
<b>51.45</b>	<b>2.25</b>	 <b>24</b>	 <b>CH 11</b> Deja Rn N°38 En Poste de cemento con Letra M. <div style="border: 1px solid black; padding: 2px; width: fit-content; margin-left: auto;"> 1er. Auto  12:14 hs. </div>	<b>0.00</b>

LPE	<b>11</b>	La Cantera	Distancia		Etapa 2	Pag.
CH	<b>11A</b>	Flexi Service - Ingreso	<b>16.06</b>			<b>45</b>
			kms.		Sector 21	
Nro.	PRUEBA ESPECIAL		Kms.	Promedio	Tiempo Otorgado	
<b>11/13</b>	La Cantera Catamarca		<b>4.85</b>	<b>38.54</b>	<b>25'</b>	
				kms.		

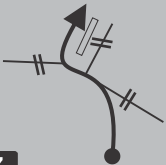

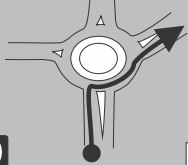







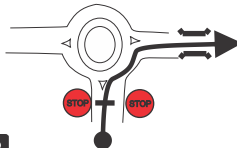

Distancia		Dirección	Información	Distancia Regresiva
Total	Parcial			
0.00	0.00	 1	<b>LPE 11/13</b> En poste de alabrado con Letra B. <div style="border: 1px solid black; padding: 2px; display: inline-block;">           GPS:            S 28 30 996            W 65 47 274            ALT. 492         </div> <div style="border: 1px solid black; padding: 2px; display: inline-block;">           1er. Auto            11:59 hs         </div>	16.06
1.26	1.26	 2	<b>Chicana Fuera del Camino. Por atrás de Columna de cemento.</b>	14.80
1.80	0.54	 3		14.26
2.55	0.75	 4		13.51
2.80	0.25	 5		13.26
3.00	0.20	 6		13.06

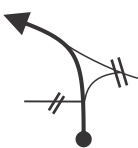





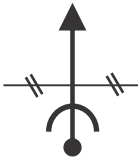





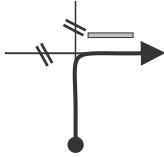

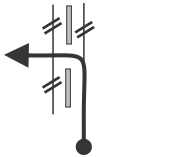
LPE	<b>11</b>	La Cantera	Distancia	Etapa 2	Pag.
CH	<b>11A</b>	Flexi Service - Ingreso	<b>16.06</b> kms.	Sector 21	<b>46</b>
Nro.	PRUEBA ESPECIAL		Kms.	Promedio	Tiempo Otorgado
<b>11/13</b>	La Cantera Catamarca		<b>4.85</b>	<b>38.54</b> kms.	<b>25'</b>

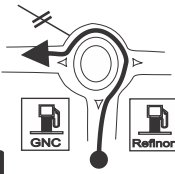
Distancia		Dirección	Información	Distancia Regresiva
Total	Parcial			
<b>3.50</b>	<b>0.50</b>	 7 <span style="float: right;">1.35</span>	Por Boulevard	<b>12.56</b>
<b>3.70</b>	<b>0.20</b>	 8 <span style="float: right;">1.15</span>	Cambia de Mano	<b>12.36</b>
<b>3.88</b>	<b>0.18</b>	 9 <span style="float: right;">0.97</span>	Cambia de Mano	<b>12.18</b>
<b>4.20</b>	<b>0.32</b>	 10 <span style="float: right;">0.65</span>	Continúa por Boulevard por carril derecho	<b>11.86</b>
<b>4.45</b>	<b>0.25</b>	 11 <span style="float: right;">0.40</span>		<b>11.61</b>
<b>4.85</b>	<b>0.40</b>	 12 <span style="float: right;">0.00</span>	 <b>FPE 11/13</b> En poste de alumbrad con letra B. <div style="border: 1px solid black; padding: 2px; margin-top: 5px;">             GPS:              S 28 29 843              W 65 48 993              ALT. 562           </div>	<b>11.21</b>





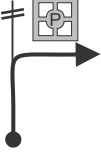





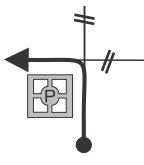

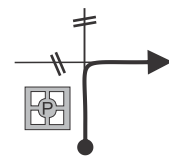
LPE	<b>11</b>	La Cantera	Distancia	Etapa 2	Pag.
CH	<b>11A</b>	Flexi Service - Ingreso	<b>16.06</b> kms.	Sector 21	<b>47</b>
Nro.	PRUEBA ESPECIAL		Kms.	Promedio	Tiempo Otorgado
<b>11/13</b>	La Cantera Catamarca		<b>4.85</b>	<b>38.54</b> kms.	<b>25'</b>

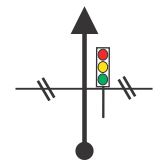
Distancia		Dirección	Información	Distancia Regresiva
Total	Parcial			
<b>5.09</b>	<b>0.24</b>	 <p><b>13</b></p>	 Frente a Casilla	<b>10.97</b>
<b>5.50</b>	<b>0.41</b>	 <p><b>14</b></p>	 Zona Urbana	<b>10.56</b>
<b>6.90</b>	<b>1.40</b>	 <p><b>15</b></p>	 Zona Urbana	<b>9.16</b>
<b>7.00</b>	<b>0.10</b>	 <p><b>16</b></p>	 Zona Urbana	<b>9.06</b>
<b>7.05</b>	<b>0.05</b>	 <p><b>17</b></p>	Continúa por calle Bonifacio Cobacho  Zona Urbana	<b>9.01</b>
<b>7.95</b>	<b>0.90</b>	 <p><b>18</b></p>	 Zona Urbana	<b>8.11</b>

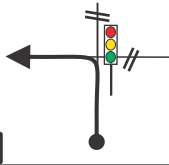
LPE	<b>11</b>	La Cantera	Distancia	Etapa 2	Pag.
CH	<b>11A</b>	Flexi Service - Ingreso	<b>16.06</b> kms.	Sector 21	<b>48</b>
Nro.	PRUEBA ESPECIAL		Kms.	Promedio	Tiempo Otorgado
<b>11/13</b>	La Cantera Catamarca		<b>4.85</b>	<b>38.54</b> kms.	<b>25'</b>

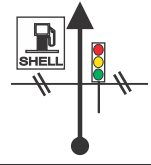
Distancia		Dirección	Información	Distancia Regresiva
Total	Parcial			
<b>8.23</b>	<b>0.28</b>	 19	Por Av. Manuel Navarro  Zona Urbana	<b>7.83</b>
<b>8.33</b>	<b>0.10</b>	 20	Por calle Manuel Pedraza  Zona Urbana	<b>7.73</b>
<b>8.85</b>	<b>0.52</b>	 21	Por Av. Hipólito Yrigoyen  Zona Urbana	<b>7.21</b>
<b>9.50</b>	<b>0.65</b>	 22	Continúa por Av. Hipólito Yrigoyen  Zona Urbana	<b>6.56</b>
<b>9.73</b>	<b>0.23</b>	 23	Semáforo  Zona Urbana	<b>6.33</b>
<b>10.88</b>	<b>1.15</b>	 24	 Zona Urbana	<b>5.18</b>



LPE	<b>11</b>	La Cantera	Distancia	Etapa 2	Pag.
CH	<b>11A</b>	Flexi Service - Ingreso	<b>16.06</b>	Sector 21	<b>49</b>
			kms.		
Nro.	PRUEBA ESPECIAL		Kms.	Promedio	Tiempo Otorgado
<b>11/13</b>	La Cantera Catamarca		<b>4.85</b>	<b>38.54</b>	<b>25'</b>
				kms.	

Distancia		Dirección	Información	Distancia Regresiva
Total	Parcial			
<b>10.98</b>	<b>0.10</b>	 <b>25</b>	Por calle Salta  Zona Urbana	<b>5.08</b>
<b>11.10</b>	<b>0.12</b>	 <b>26</b>	Por Av. Guemes  Zona Urbana	<b>4.96</b>
<b>11.20</b>	<b>0.10</b>	 <b>27</b>	Semáforo Cruza calle Tucumán  Zona Urbana	<b>4.86</b>
<b>11.83</b>	<b>0.63</b>	 <b>28</b>	Semáforo Por Av. Alen  Zona Urbana	<b>4.23</b>
<b>12.85</b>	<b>1.02</b>	 <b>29</b>	 Zona Urbana	<b>3.21</b>
<b>13.00</b>	<b>0.15</b>	 <b>30</b>	 Zona Urbana	<b>3.06</b>

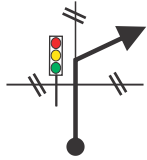
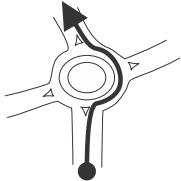
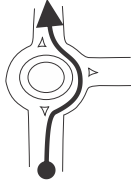
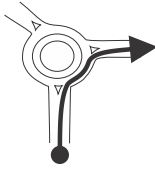
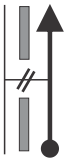
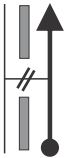
LPE	<b>11</b>	La Cantera	Distancia	<b>16.06</b>	Etapa 2	Pag.
CH	<b>11A</b>	Flexi Service - Ingreso	kms.		Sector 21	<b>50</b>
Nro.	PRUEBA ESPECIAL		Kms.	Promedio	Tiempo Otorgado	
<b>11/13</b>	La Cantera Catamarca		<b>4.85</b>	<b>38.54</b>	<b>25'</b>	
			kms.	kms.		

Distancia		Dirección	Información	Distancia Regresiva
Total	Parcial			
<b>13.50</b>	<b>0.50</b>	 <b>31</b>	<b>Semáforo</b> Cruza Av. Belgrano	<b>2.56</b>
<b>14.60</b>	<b>1.10</b>	 <b>32</b>		<b>1.46</b>
<b>15.09</b>	<b>0.49</b>	 <b>33</b>		<b>0.97</b>
<b>15.58</b>	<b>0.49</b>	 <b>34</b>		<b>0.48</b>
<b>15.83</b>	<b>0.25</b>	 <b>35</b>		<b>0.23</b>
<b>15.93</b>	<b>0.10</b>	 <b>36</b>		<b>0.13</b>

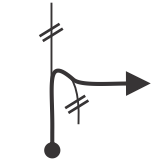
<b>LPE</b>	<b>11</b>	<b>La Cantera</b>	<b>Distancia</b>	<b>Etapa 2</b>	<b>Pag.</b>
<b>CH</b>	<b>11A</b>	<b>Flexi Service - Ingreso</b>	<b>16.06</b> kms.	<b>Sector 21</b>	<b>51</b>
<b>Nro.</b>	<b>PRUEBA ESPECIAL</b>		<b>Kms.</b>	<b>Promedio</b>	<b>Tiempo Otorgado</b>
<b>11/13</b>	<b>La Cantera Catamarca</b>		<b>4.85</b>	<b>38.54</b> kms.	<b>25'</b>



Distancia		Dirección	Información	Distancia Regresiva
Total	Parcial			
<b>16.00</b>	<b>0.07</b>	 <b>37</b>		<b>0.06</b>
<b>16.06</b>	<b>0.06</b>	 <b>38</b>	 <b>CH 11A</b> Ingreso - Flexi Service Predio Ferial Catamarca PORTON N°7 GPS: S 28 26 891 W 65 45 338 ALT. 533	<b>0.00</b>

CH	11D	Reagrupamiento - Salida	Distancia	Etapa 2	Pag.
CH	12	El Portezuelo	13.38	Sector 24	52
			kms.		
Nro.	PRUEBA ESPECIAL		Kms.	Promedio	Tiempo Otorgado
	<b>ENLACE</b>			40.14	20'
			kms.		

Se repite ídem a páginas 27, 28, 29 y 30.

LPE	12	El Portezuelo	Distancia	Etapa 2	Pag.
CH	13	San Pedro	26.29	Sector 25	
			kms.		
Nro.	PRUEBA ESPECIAL		Kms.	Promedio	Tiempo Otorgado
8/12	El Portezuelo Ruta 33		12.00	52.58	30'
			kms.		

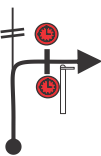
Se repite ídem a páginas 31, 32, 33 y 34 (hasta Figura 21).

Distancia		Dirección	Información	Distancia Regresiva
Total	Parcial			
26.29	1.05		 <b>CH 13</b> Deja Rn N°38 En Poste de cemento con Letra M.	0.00
		22	1er. Auto 14:40 hs.	

LPE	13	La Cantera	Distancia	Etapa 2	Pag.
CH	13A	Parque Cerrado Final - Ingreso	16.06	Sector 26	
			kms.		
Nro.	PRUEBA ESPECIAL		Kms.	Promedio	Tiempo Otorgado
11/13	La Cantera Catamarca		4.85	38.54	25'
			kms.		

Se repite ídem a páginas 45, 46, 47, 48, 49, 50 y 51.



PILOTO						
N°						
PE 1	<input type="text"/>	<input type="text"/>	<input type="text"/>	<input type="text"/>	<input type="text"/>	<input type="text"/>
PE 2	<input type="text"/>	<input type="text"/>	<input type="text"/>	<input type="text"/>	<input type="text"/>	<input type="text"/>
PE 3	<input type="text"/>	<input type="text"/>	<input type="text"/>	<input type="text"/>	<input type="text"/>	<input type="text"/>
PE 4	<input type="text"/>	<input type="text"/>	<input type="text"/>	<input type="text"/>	<input type="text"/>	<input type="text"/>
PE 5	<input type="text"/>	<input type="text"/>	<input type="text"/>	<input type="text"/>	<input type="text"/>	<input type="text"/>
PE 6	<input type="text"/>	<input type="text"/>	<input type="text"/>	<input type="text"/>	<input type="text"/>	<input type="text"/>
PE 7	<input type="text"/>	<input type="text"/>	<input type="text"/>	<input type="text"/>	<input type="text"/>	<input type="text"/>
TIEMPO 1ra. Etapa						





PILOTO						
N°						
TIEMPO 1ra. Etapa	<input type="text"/>	<input type="text"/>	<input type="text"/>	<input type="text"/>	<input type="text"/>	<input type="text"/>
PE 8	<input type="text"/>	<input type="text"/>	<input type="text"/>	<input type="text"/>	<input type="text"/>	<input type="text"/>
PE 9	<input type="text"/>	<input type="text"/>	<input type="text"/>	<input type="text"/>	<input type="text"/>	<input type="text"/>
PE 10	<input type="text"/>	<input type="text"/>	<input type="text"/>	<input type="text"/>	<input type="text"/>	<input type="text"/>
PE 11	<input type="text"/>	<input type="text"/>	<input type="text"/>	<input type="text"/>	<input type="text"/>	<input type="text"/>
PE 12	<input type="text"/>	<input type="text"/>	<input type="text"/>	<input type="text"/>	<input type="text"/>	<input type="text"/>
PE 13	<input type="text"/>	<input type="text"/>	<input type="text"/>	<input type="text"/>	<input type="text"/>	<input type="text"/>
TIEMPO TOTAL						

Nólas

Fecha

Fecha

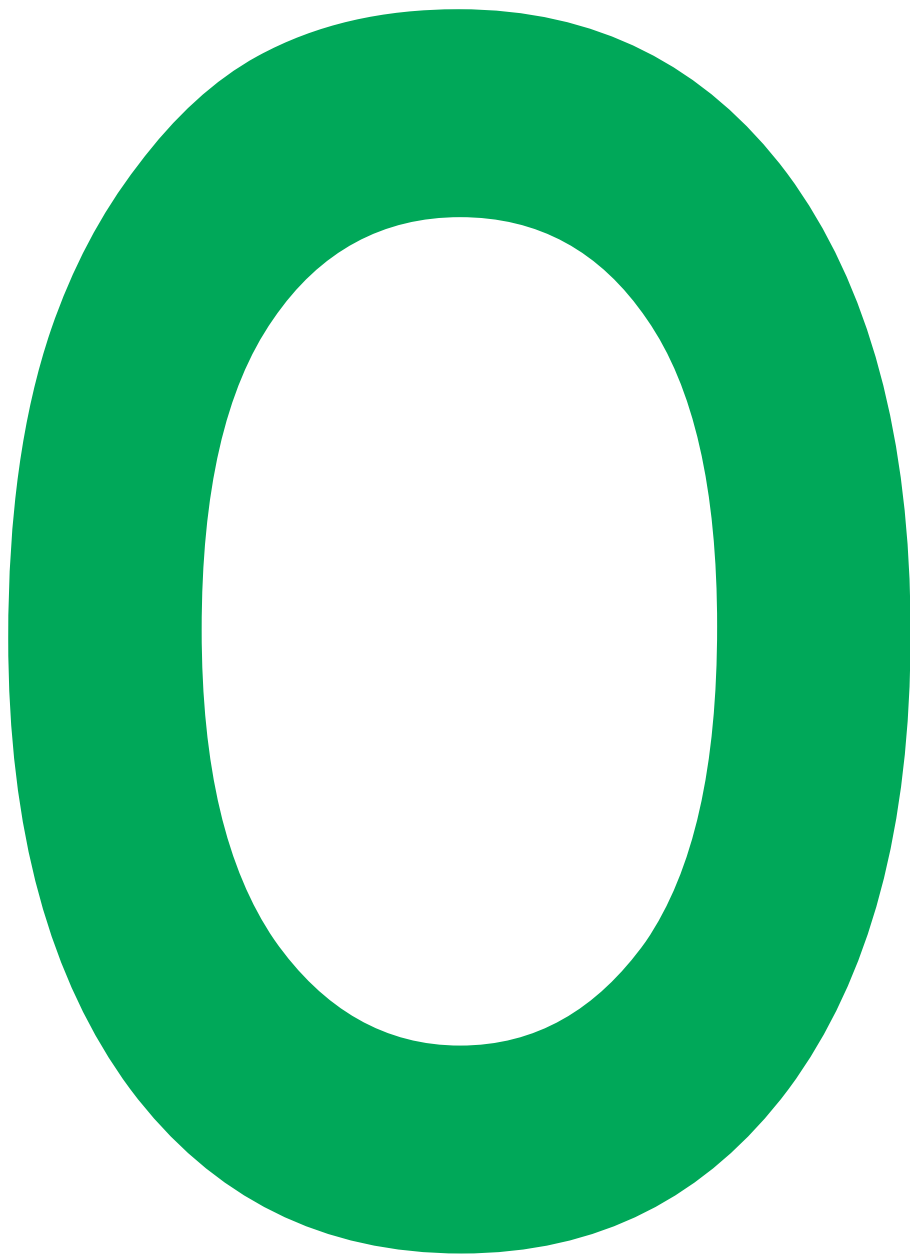

**MUESTRE ESTE SIGNO A  
TRIPULACIONES SI N  
ATENCION MEDICA**

**SOC**

**MUESTRE ESTE SIGNO A  
TRIPULACIONES SI  
ATENCION MEDICA**